

# Performance, Sustainability, Safety.

It is a fast-moving and often complex environment for buyers of precision cleaning solutions. Fortunately there is no longer a need to trade-off performance for sustainability and safety. This white paper examines how 3M™ Novec™ Engineered Fluids are helping businesses achieve many goals with one single solution.

Novec engineered fluids are commercialised via the Electronics Materials Solutions Division at 3M. The division has developed a wide variety of solutions based on 13 key technology platforms, which enable next generation technology in semiconductor, electronic devices, signal management and data centres. 3M's diversity in electronics provides a broad understanding of our customers' needs and the expertise to create solutions that address multiple challenges and markets.

Novec fluids are an example of a technology used across a range of applications, including heat transfer, cleaning, coatings, clean fire extinguishing, battery materials and more. Within the aerospace market, for example, customers can potentially use Novec fluids for surface treatment, cleaning of engine parts or precision bearings, and cleaning prior to coating of printed circuit boards for protection against moisture or corrosion.

## **Novec engineered fluids: the chemistry**

Based on 3M proprietary segregated hydrofluoroether (HFE) chemistry, Novec fluids have many properties that contribute to their diverse use. They have excellent dielectric properties and a wide range of boiling points, which makes them suitable for many heat transfer applications, both single and phase change. They are inert with very low surface tension. This allows them to evenly coat or clean irregular surfaces, penetrating complex geometries and low profile components.

Various cleaning applications are addressed with both neat Novec fluids, and also with azeotropic mixtures which use neat Novec fluids plus TDE (trans-1,2 dichloroethylene) to increase the solvent power. Indeed, neat fluorinated fluids all exhibit relatively poor solvency. TDE is a chlorinated solvent which is incorporated in several Novec fluids used in precision cleaning applications. TDE is not classed as a CMR (Carcinogenic, Mutagenic, Reprotoxic). This, combined with its favourable environmental properties, clearly differentiates it from traditional chlorinated solvents such as trichloroethylene (Trike), perchloroethylene (Perc) and methylenechloride.

HFEs make the mixtures non-flammable and more efficient for cleaning complex geometries, thanks to their low surface tension. These properties, combined with low vapour diffusion rates, high liquid density and boiling points range (from 41 to 76°C), mean Novec engineered fluids are easily incorporated into typical vapour degreasing equipment. They are easily contained and recirculated in these machines, avoiding loss of product. A

## Cleaning process equipment monosolvent

vapour phase cleaning process has multiple benefits – short cycle time, and ease of use with consistent results in cleaning (1), rinsing (2) and drying (3) (as can be seen in the diagram below).

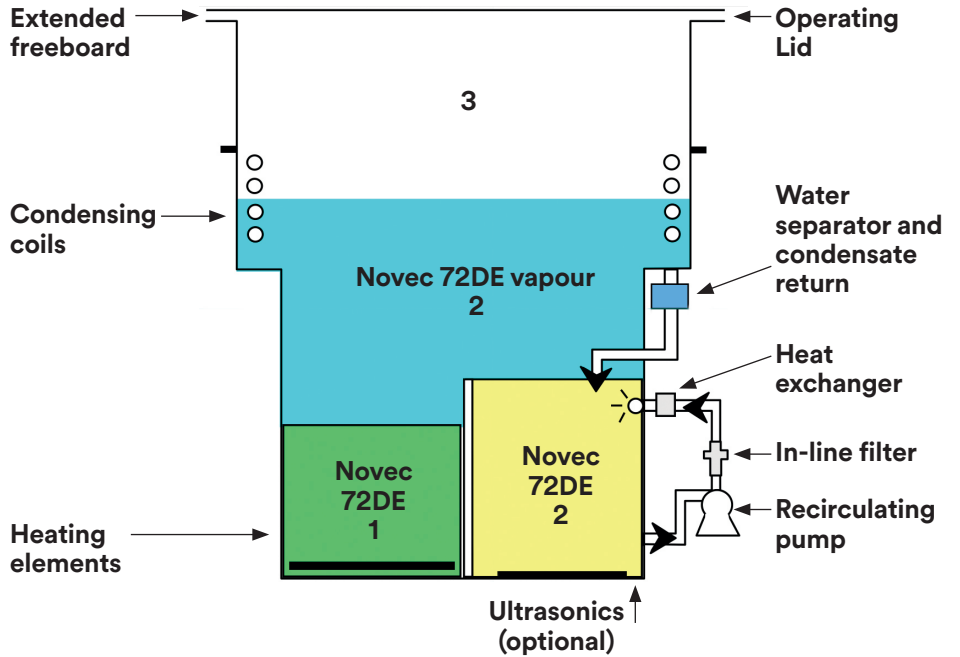

3M™ Novec™ Engineered Fluids are also suitable for use in a co-solvent process.

## Cleaning applications in the aerospace market



When selecting a cleaning solvent for an aerospace application, materials compatibility is as important as the solvent's performance. Novec engineered fluids are generally compatible with the following materials (users should evaluate parts containing some plastics and elastomers for long-term compatibility):

Metals	Plastics	Elastomers
Aluminium	Epoxy	Polysulphide
Copper	Nylon	Chlorosulphonated
Carbon steel	PTFE	EPDM
302 Stainless steel	Polyethylene	Buna-S*
Brass	Polypropylene	Butyl rubber*
Zinc	Polyester	Natural rubber*
Molybdenum	Phenolic	
Tantalum		
Titanium		
Tungsten		
Cu/Be alloy C 172		
Magnesium alloy AZ31B		

Novec engineered fluids are compatible with a wide range of substrates found on an aircraft, including titanium, aluminium and their alloys. This, and the fact that Novec fluids evaporate quickly without residue, makes them suitable for use as both general purpose cleaning solvents and in specialised applications, such as hydraulic and oxygen system cleaning, engine parts cleaning and avionics cleaning.

\*Some swelling

## 3M™ Novec™ Products – Aeronautics and Military Compatibility tests

### 3M™ Novec™ Engineered Fluid compatibility test results\*

Test description	ASTM#	3M™ Novec™ 7100 Engineered Fluid	3M™ Novec™ 71DE Engineered Fluid	3M™ Novec™ 7200 Engineered Fluid	3M™ Novec™ 72DE Engineered Fluid
Sandwich corrosion T	F1110	Conforms	Conforms	Conforms	Conforms
Acrylic stress crazing	F484	Conforms	Doesn't conform**	Conforms	Doesn't conform
Paint softening test	F502	Conforms	Conforms	Conforms	Conforms
Hydrogen embrittlement	F519	Conforms	Conforms	Conforms	Conforms
Hydrogen embrittlement	F519-77	Conforms	Conforms	Conforms	Conforms
Hydrogen embrittlement	F519, 1C	Conforms	Conforms	Conforms	Conforms
Residue test	F483	Conforms	Conforms	Conforms	Conforms
Immersion corrosion test	F483	Conforms	Conforms	Conforms	Conforms
Cadmium removal test	F483	Conforms	Conforms	Conforms	Conforms
Low embrittling cadmium plate	F111	Conforms	Conforms	Conforms	Conforms
Flash point	D56	Conforms	Conforms	Conforms	Conforms
Stress corrosion	F945	Conforms	Conforms	Conforms	Conforms

\* Novec engineered fluids that contain TDE are generally compatible with most materials. However users should evaluate parts containing some plastics and elastomers for long term compatibility prior to first use

\*\* Novec 71DE and Novec 72DE fluids caused visible stress to the acrylic plastics. Testing performed by Scientific Materials, Inc.

## Specifications for 3M™ Novec™ Engineered Fluids

	3M™ Novec™ 7100 Engineered Fluid	3M™ Novec™ 71DE Engineered Fluid	3M™ Novec™ 71IPA Engineered Fluid	3M™ Novec™ 72DA Engineered Fluid	3M™ Novec™ 72DE Engineered Fluid	3M™ Novec™ 7200 Engineered Fluid	Comment
<b>Engine Manufacturers</b>							
	✓	✗	✓	✗	✗	✗	Vapour phase cleaning
	✗	✗	✗	✗	✓	✗	Cleaning of engine turbine blades. Cleaning of hydraulic cylinders for flaps and tails. Product approved but no specification.
	✗	✗	✓	✗	✗	✗	Removing hydraulic fluid from hot engines after testing. Product approved but no specification.
<b>Aircraft Manufacturers</b>							
Boeing	D6 17487(1)	D6 17487*	✗	D6 17487*	D6 17487*	D6 17487*	Exterior and general cleaning. *Stating exception of acrylic stress crazing evaluation of materials developed for use in general maintenance of Boeing airplane
Boeing	BSS7074 (revB)	✗	✗	✗	✗	✗	Leak-detecting systems
Boeing	BAC 5750	BAC 5750	✗	✗	✗	✗	Solvent cleaning
Boeing	BAC 5402	BAC 5402	✗	✗	✗	✗	Oxygen tool cleaning
Boeing	BAC 5001-3	✗	✗	✗	✗	✗	Tube bending
Boeing	BSS 7074	✗	✗	✗	✗	✗	Leak testing of fuel systems
Boeing	✗	✗	✗	✗	✓	✗	Cleaning grinding compounds from aluminum tubes prior to welding. Product approved but no specification
	✓	✓	✗	✗	✗	✗	Oxygen and hydraulic systems
Gulfstream Aerospace	GAS 115PC	✗	✗	✗	✗	✗	Solvent compound – cleaner/degreaser. 3M™ Novec™ Contact Cleaner also approved under this specification.
<b>Aerospace Specifications</b>							
NASA Orbitec Spec	SES 0073	✗	✗	✗	✗	✗	Oxygen system
ADS 61 PRS	✓	✓	✗	✗	✓	✗	AAMCDM
Mil std 1330D	1330D	✗	✗	✗	✗	✗	Oxygen system gauge cleaning
Aerospace/Mil Spec 1526B	1526B	1526B*	✗	1526B*	1526B*	1526B*	Cleaner for aircraft exterior surface. *Stating exception of acrylic stress crazing for aerotrope products.
CID-A-A59150Rev A	✓	✗	✗	✗	✗	✗	Commercial item description (Government document) for Novec 7100 fluid primarily for cleaning oxygen systems.



Where avionics are concerned, reliability and a very high level of cleanliness is key. Many aerospace customers globally are achieving this with 3M™ Novec™ Engineered Fluids.

The attributes of Novec engineered fluids make them equally suitable for precision cleaning in the electronics market. Due to evolving design in electronics and miniaturisation (e.g. small spaces between components, low stand offs...), cleaning of PCBs is a particularly challenging application.

## Use in the Electronics Market

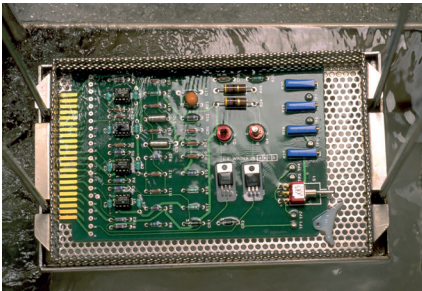

Novec engineered fluids are widely used in electronics for precision cleaning and protection of PCBs against oils, fluxes and other residues. With their extremely low surface tension, Novec fluids easily penetrate tight spaces on complex parts and underneath low stand-off components. They drain off easily and offer fast, spot-free drying avoiding risk of corrosion.

Where the process is concerned, vapour phase cleaning is the most efficient, because it is based on a close loop system, maintaining high cleaning product quality and significantly limiting solvent losses.

Precision cleaning with Novec engineered fluids is a viable alternative to aqueous cleaning, as it requires reduced power consumption and no need for waste water treatment. It is also significantly faster, due to a shorter drying time. A smaller equipment footprint is required with no need for drying equipment, and overall cleaning is often improved for various materials and particularly for complex parts. Although aqueous cleaning is often considered to be an environmentally sound choice, the sheer quantities of water involved can have a considerable environmental impact, particularly in countries subject to water shortages. Preservation of natural resources is becoming a key requirement for end users when selecting a cleaning process.

Worker safety is another key driver for companies to adopt sustainable products like Novec engineered fluids, instead of solvents like nPB which are subject to stringent regulations (including REACH and industrial hygiene regulations from ACGIH) and are gradually being phased out.

For a manufacturer of electrical components for aircraft, industrial, marine and space uses, it was the company's EHS policy that dictated a switch from nPB to 3M™ Novec™ 72DE Engineered Fluid. The company was using nPB to remove oils from stamped metal parts, and flux from cabling and circuit boards. Novec fluid offered a low toxicity alternative that combined equivalent or improved cleaning with outstanding EHS properties.

Similarly, for an aircraft control and diagnostics systems manufacturer, the switch from HCFC-141b (which was banned end of 2007) was driven by the need to source a non-ozone depleting, low Global Warming Potential alternative. In addition to its environmental profile, a Novec engineered fluid was selected for its wide range of materials compatibility, plus its cleaning performance. Use of Novec engineered fluid resulted in more efficient cleaning of flux removal from printed circuit boards, with less solvent used.

## Sustainability

Based on 3M proprietary segregated hydrofluoroether and fluoroketone chemistry, Novec fluids have an outstanding environmental profile. Novec fluids have an Ozone Depletion Potential of zero meaning they have no effect on stratospheric ozone. They also have low Global Warming Potential when compared with other solvents such as hydrofluorocarbons (HFCs) etc.

The environmental profile of 3M™ Novec™ Engineered Fluids has led to wide acceptance for commercial use by regulatory agencies in the United States, Canada, Japan, Korea, Australia, Europe, the Philippines and China. 3M™ Novec™ 7100 Engineered Fluid and 3M™ Novec™ 7200 Engineered Fluid have been approved without restrictions under the Significant New Alternatives Policy (SNAP) program of the U.S. EPA. In Europe they are not listed in Annex I of the F-Gas Regulation (EU 517/2014), meaning they are not restricted or banned for use within the EU.

3M is recognised as a responsible supplier and has been a member of the Dow Jones Sustainability Index since its inception in 1999. RobecoSAM and S&P Dow Jones Indices evaluate 3500 global companies across different markets in this sustainability benchmark, with only 10% of candidates finally accepted for this classification. 3M is also a signatory member of the United Nations Global Compact, supporting its 10 principles in human rights, labour, environment and anti-corruption. 3M continues to invest in Research & Development in the area of clean chemical agents, to develop technology with an even lower environmental footprint.

## Safety

Novec engineered fluids offer a wider margin of safety than other alternative solvents and don't require any specific handling conditions in standard use. Novec 7100 engineered fluid and Novec 7200 engineered fluid are classified as 750 ppm and 200 ppm (parts per million) respectively in terms of exposure limits. Solvents such as Perchloroethylene, HFCs, Methylene Chloride and Trike have exposure limits as low as 10ppm.

Moreover, thanks to the favourable toxicity profile, Novec fluids exhibit higher maximum emission limits according to the IED 2010/75/EU Directive, which includes the VOC 1999/13/EC. Lower exposure limits can necessitate investment in enclosed vapour degreasing systems, whereas Novec fluids do not require extraction.

Extensive peer-reviewed toxicity testing has been conducted on Novec engineered fluids. Novec fluids are not classed as CMR and do not carry the carcinogenic risk phrases carried by Perc, Methylene Chloride, nPB or Trike.

Novec engineered fluids are not irritating to the eyes or skin and have tested negative in all mutagenicity screens. In contrast, nPB based solvents are classed as CMRs by the Solvent Emissions Directive. Methylene Chloride & Perc are classed as Category 3 Carcinogenics, and Trike a Category 2.

## Flammability

Novec engineered fluids and their azeotropes are non-flammable in their liquid phase thanks to the absence of a flash point. Under normal operating conditions in a vapour degreaser, Novec fluids are non-flammable even when exposed to a direct flame or an electrical arc.

## Summary: considerations in evaluating solvents

There are three key dimensions to consider in precision cleaning: Performance, Safety and Environmental factors. In the past, Performance was arguably the single most important parameter. Indeed, for aerospace, electronics and other markets, surface tension is still critical in the cleaning of complex parts (fine pitch components, lower backspace etc)

Due to the increasing influence of regulations in this market, and the overall awareness of organisations' environmental footprint, it is also important to choose a solution that has the highest margin of safety, is not subject to current regulations, and performs effectively. 3M™ Novec™ Engineered Fluids strike a balance between all these demands. 3M continues to innovate and commercialise additional fluids in the 3M™ Novec™ range that meet our customers' demanding and evolving needs in precision cleaning.

## Novec Engineered Fluids – the right balance on performance, safety and environment

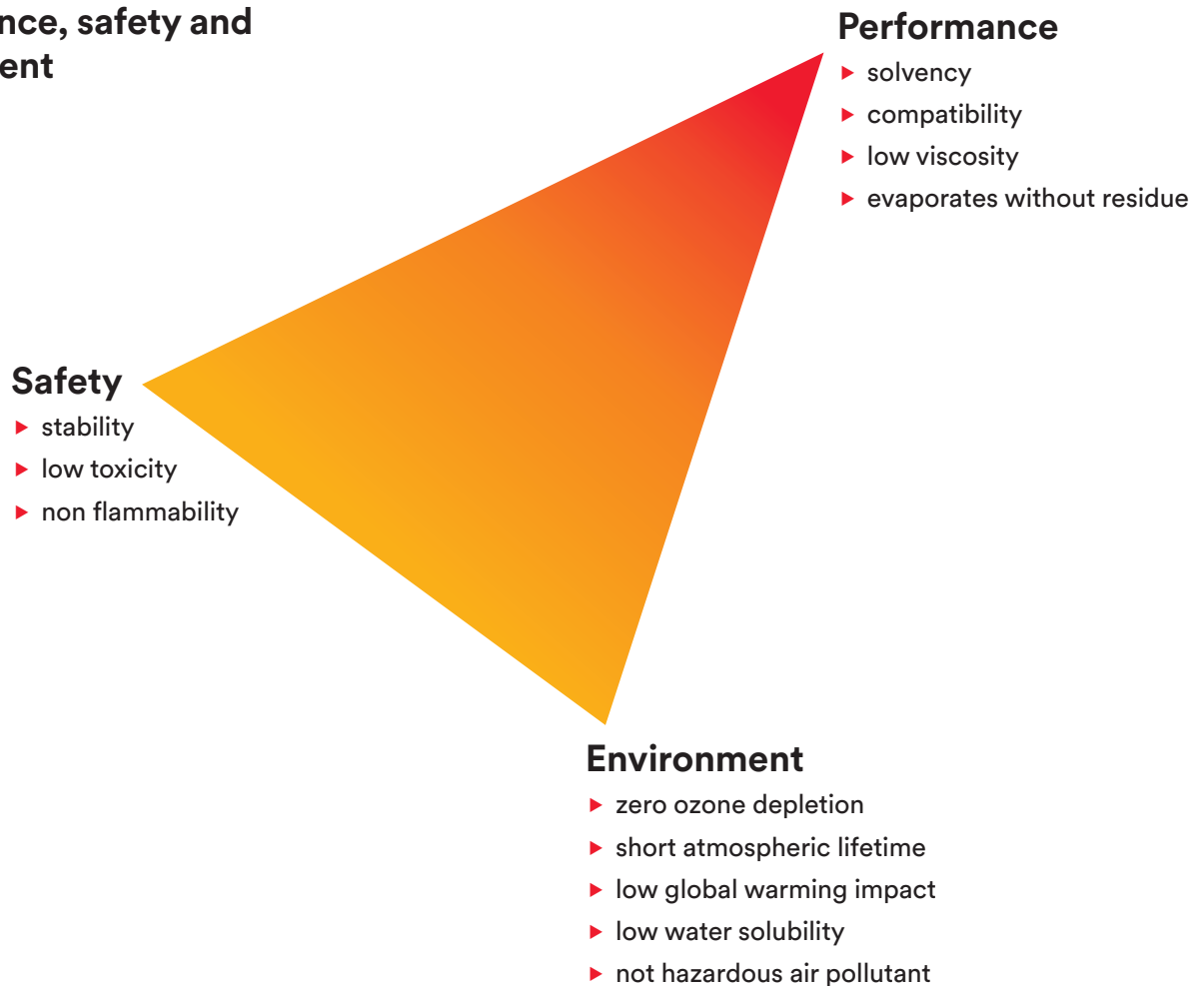

Regulatory: For regulatory information about this product, contact your 3M representative.

Technical Information: The technical information, recommendations and other statements contained in this document are based upon tests or experience that 3M believes are reliable, but the accuracy or completeness of such information is not guaranteed.

Product Use: Many factors beyond 3M's control and uniquely within user's knowledge and control can affect the use and performance of a 3M product in a particular application. Given the variety of factors that can affect the use and performance of a 3M product, user is solely responsible for evaluating the 3M product and determining whether it is fit for a particular purpose and suitable for user's method of application.

Warranty, Limited Remedy, and Disclaimer: Unless an additional warranty is specifically stated on the applicable 3M product packaging or product literature, 3M warrants that each 3M product meets the applicable 3M product specification at the time 3M ships the product. 3M MAKES NO OTHER WARRANTIES OR CONDITIONS, EXPRESS OR IMPLIED, INCLUDING, BUT NOT LIMITED TO, ANY IMPLIED WARRANTY OR CONDITION OF SUITABILITY OR FITNESS FOR A PARTICULAR PURPOSE OR ANY IMPLIED WARRANTY OR CONDITION ARISING OUT OF A COURSE OF DEALING, CUSTOM OR USAGE OF TRADE. If the 3M product does not conform to this warranty, then the sole and exclusive remedy is, at 3M's option, replacement of the 3M product or refund of the purchase price.

Limitation of Liability: Except where prohibited by law, 3M will not be liable for any loss or damage arising from the 3M product, whether direct, indirect, special, incidental or consequential, regardless of the legal theory asserted, including warranty, contract, negligence or strict liability.



**UK**  
3M Electronics Materials  
Solutions Division  
0800 032 0841

**Baltics**  
3M Lithuania  
370 5216 0780

**Belgium**  
3M Belgium  
32 3 250 7521

**France**  
3M France  
33 1303 16161

**Germany**  
3M Germany  
49 2131 140

**Italy**  
3M Italy  
39 2 70351

**Spain**  
3M Spain  
34 91 3216000

**Sweden**  
3M Sweden  
46 08 922100

**Switzerland**  
3M Switzerland  
41 1 7249090